

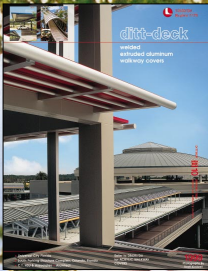

08625/Dit  
Buyline 1903

# ditt-dome

acrylic  
walkway covers



DITTMER  
**10**  
SPECIALTIES  
aluminum walkway covers



- Canobie Lake Park
- Salem, New Hampshire

Refer to 10530/Dit  
for EXTRUDED ALUMINUM  
WALKWAY COVERS

**1999**  
Photography By  
Scott Kimbrell

- Orange County Sheriff Booking Facility
- Orlando, Florida
- Architects Design Group

- Orange County Regional Service Center
- Orlando, Florida
- Burke, Bales & Mills • Architect

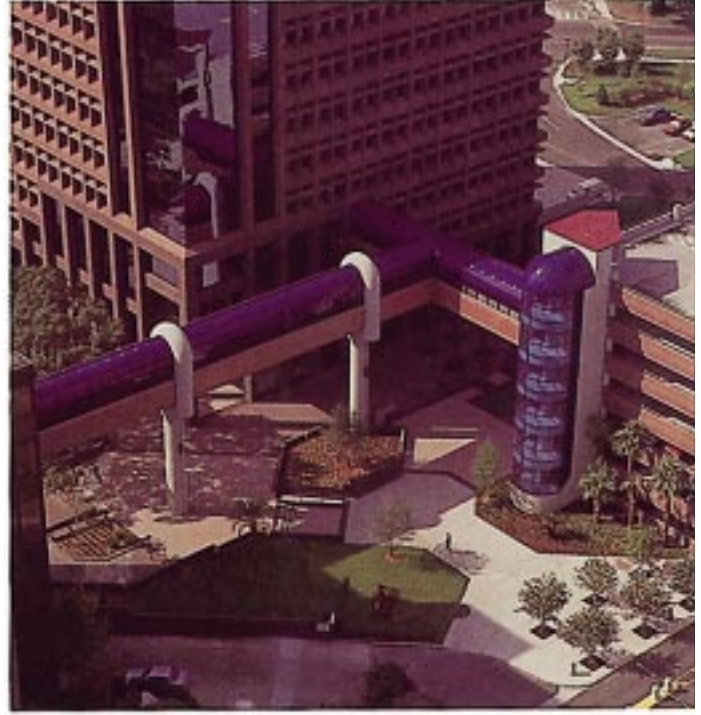

- Sea World
- Orlando, Florida
- Dean Price Architect

1006 Shepard Road • Winter Springs, FL 32708  
(407) 699-1755 • FAX (407) 695-4430  
(800) 822-1755

# ditt-dome

## details

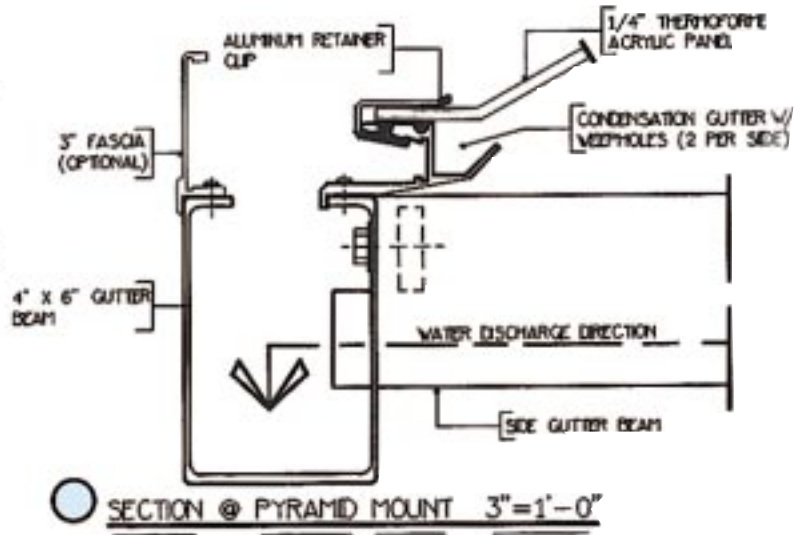
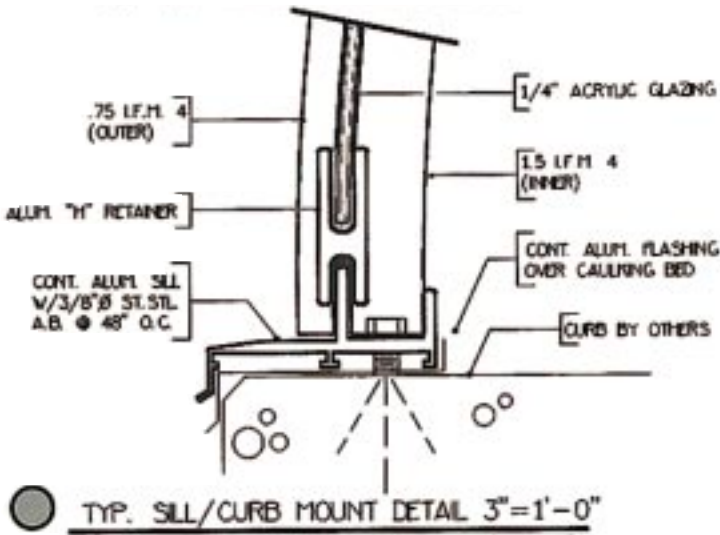
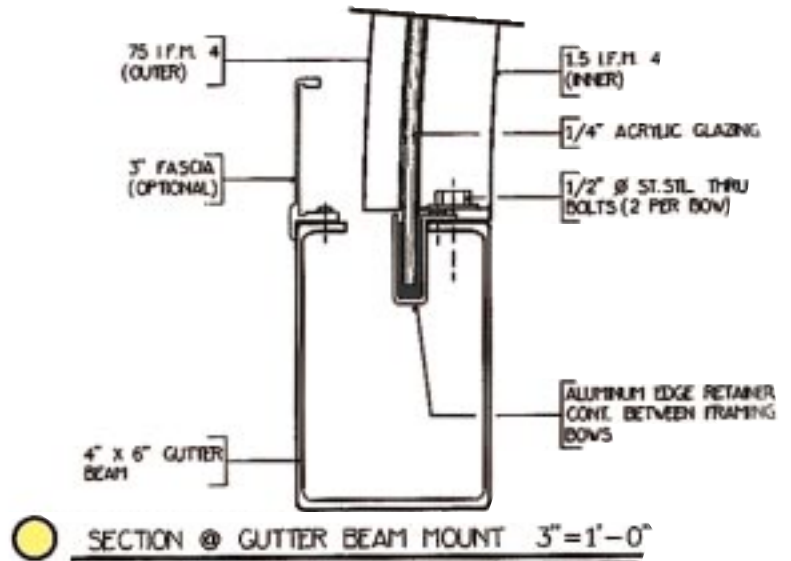
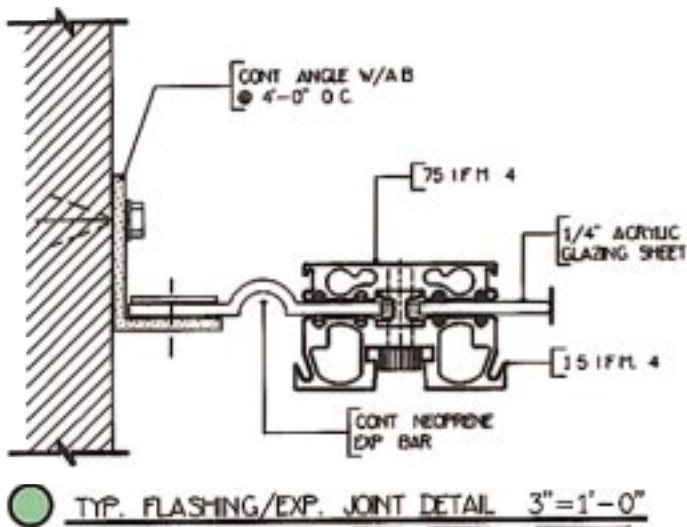
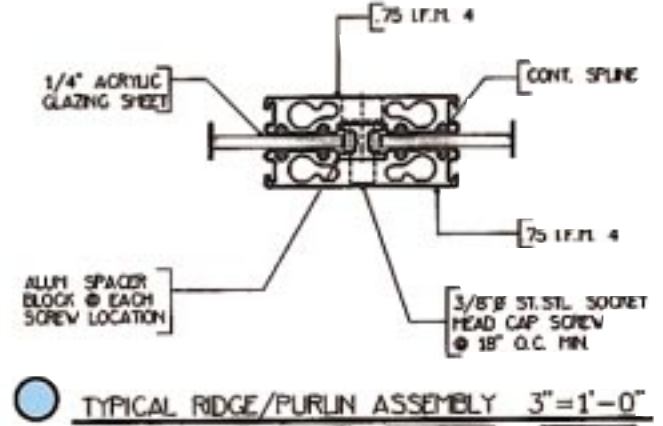
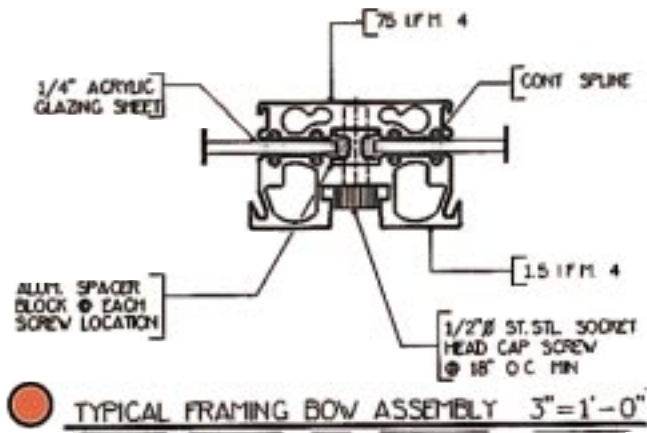

Call for our nearest representative to service your inquiries.  
800/822-1755 or Sweets Buyline 800/633-1180

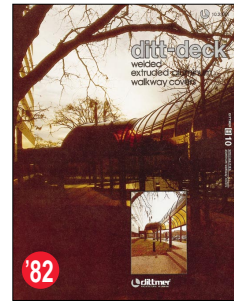
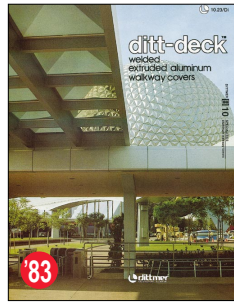
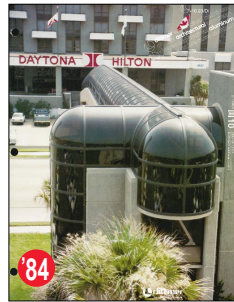
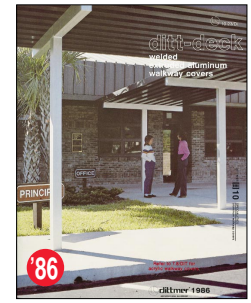
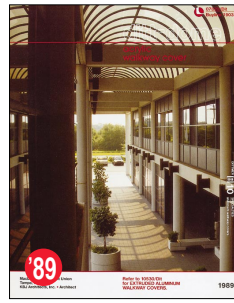
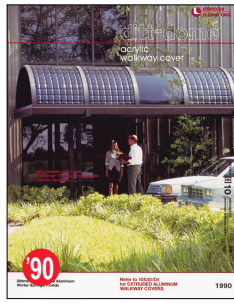
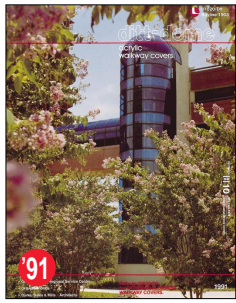
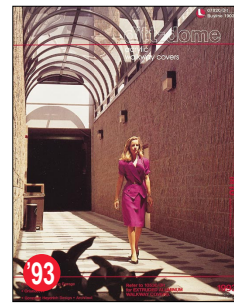
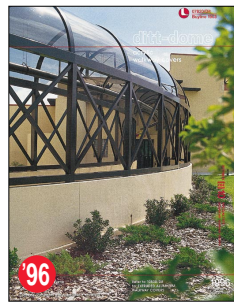
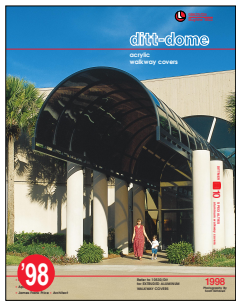

# ditt-dome

acrylic walkway covers

## specifications

**General:** DITT-DOME barrel vault, pyramid, or pillow type walkway covers shall consist of a structural framing system entirely of anodized aluminum extrusions and acrylic sheets, as manufactured by Dittmer Architectural Aluminum, 1006 Shepard Road, Winter Springs, Florida 32708, or approved equal.

**Material:** All extrusions shall be 6063 alloy heat treated to a T-6 temper. Roof panels shall be of acrylic sheet equal to Rohm & Haas Plexiglas® Type G. All fasteners to be 18-8 stainless.

**Internal Drainage:** Water flow is directed from glazing to beams and columns, as indicated by the drawings, for discharge out "weepholes" at ground level.

**Framing System:** Anodized beams and columns shall be heli-arc welded into rigid, one piece units in the manufacturer's plant. Formed framing sections shall have welded end plates for mechanical fastening to beams. Purlins shall be fastened to arches with concealed 18-8 stainless steel threaded rod and set screws. A coat of clear acrylic enamel shall be applied to insulate column ends from electrolytic reaction with grout. When size of system does not permit shipment as welded unit, mechanical joints shall be employed.

**Finish:** Standard Finish shall be satin anodize 204-R1 per Aluminum Association Specification AA-M-10C-22A-21. Hardcoat bronze, amber or black color anodizing shall be per AA-M-10C-22A-42 on KB-45 controlled billet, color to be selected. Painted Finish shall consist of baked acrylic enamel, for maximum chalk and fade resistance, over chromate conversion pretreatment. Bents, after solvent cleaning, shall receive one coat of vinyl wash-etch primer (Mil. #125-880) and a 1 mil. minimum coating of exterior grade, two-part, polyurethane for maximum abrasion resistance and maintainability. Acrylic sheets shall be clear, solar control tinted (bronze or grey), or opaque white.

**Dimensions:** General Contractor shall field-confirm bent location dimensions and elevations as shown on shop drawings prior to fabrication by Dittmer.

**Erection:** Sleeves (styrofoam block-outs) shall be furnished by Dittmer and set by General Contractor. Dittmer, or authorized installer, shall be scheduled to erect after all adjacent roofing and masonry have been completed. All concrete work, anchor bolts and/or flashing, where required, shall be by others. Bents shall be carefully aligned prior to grouting (3:1 Portland cement); downspout column interiors shall be grouted to lower edge of "weepole"; deflectors shall be installed after grouting. Butt and miter joints shall be executed in a workmanlike manner.

**Approval:** Written approval of the architect must be obtained 10 days prior to bid opening. Interested manufacturers must furnish full details of proposed product, engineering calculations on all sections involved, physical samples of all shapes, and a list of installations similar in size and design.