



10530/Dit  
Buyline 1179

# ditt-deck

welded  
extruded aluminum  
walkway covers



DITTMER  
10  
SPECIALTIES  
aluminum walkway covers

- Heart of Florida
- Davenport, Florida
- Helman Hurley Chartvat Peacock • Architect

Refer to 08625/Dit for  
ACRYLIC WALKWAY COVERS

1998

Photography By  
Scott Kimbrell



- Celebration School
- Celebration, Florida
- Schenkel Shultz • Architect



1006 Shepard Road • Winter Springs, FL 32708  
(407) 699-1755 • FAX (407) 695-4430  
(800) 822-1755

- Sumter County Judicial Building
- Bushnell, Florida
- Gee & Jenson Engineers, Architects, Planners

- Pre K Kindergarten Academy
- Houston, Texas
- Dansby & Miller Architects



- Imperial Estates Elementary
- Titusville, Florida
- Harvard, Jolly, Clees, Toppe Architects

- Titusville High School
- Titusville, Florida
- The Haskell Company • Architect



- Orlando Flite Park
- Orlando, Florida



- Heart of Florida
- Davenport, Florida
- Helman Hurley Charvat Peacock • Architect

1006 Shepard Road • Winter Springs, FL 32708  
(407) 699-1755 • FAX (407) 695-4430  
(800) 822-1755

# installation details

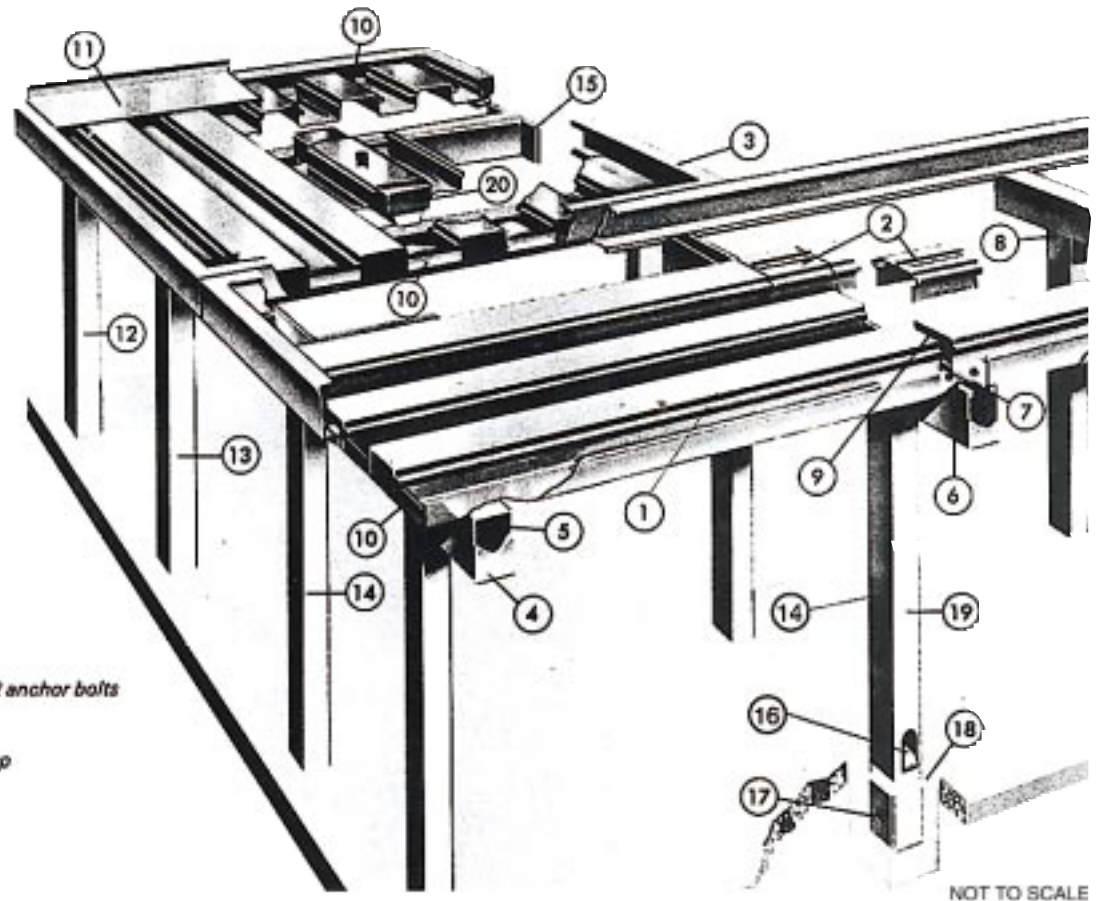

**LEGEND:**

- 1. 3.5" Deep DITT-DECK
- 2. 6" Raincap
- 3. 5" F-5 Fascia
- 4. Welded end closure
- 5. 4 x 6 Tubular beam
- 6. 4 x 6 Gutter-beam
- 7. Flared drip edge
- 8. Half-arc weld
- 9. 1" Gap for drainage
- 10. Welded "dams" in valleys
- 11. .040" Aluminum flashing
- 12. "L" Bent, Model 2
- 13. "U" Bent, Model 2
- 14. "TT" Bent, Model 2
- 15. 8" x 6" x 5/16" Aluminum plate w/ 2 anchor bolts
- 16. Weephole w/ deflector plate
- 17. 1" Diameter hole/ grout key
- 18. Grout - 3:1 Portland cement 12" deep
- 19. 4 x 4 Column penetrates grout 10"
- 20. Light Fixture

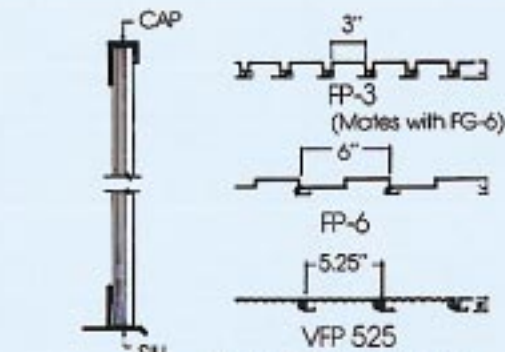

**VERTICAL FASCIA SYSTEMS**

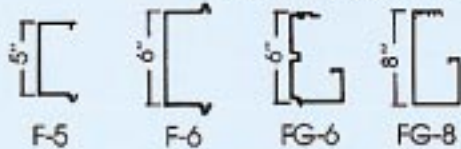

**STANDARD FASCIAS**

**fascias**

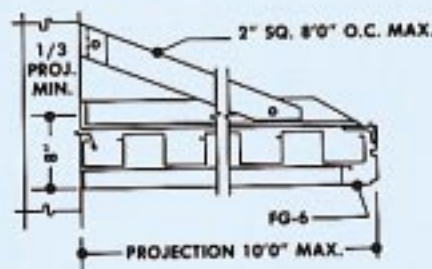

OPTION: Roof deck can run at right angle to wall w/ FG-6 fascia-gutter around perimeter.

**suspended canopies**

**DITT-DECK** Extruded Aluminum Walkway Covers enhance school, hospital and other institutional architecture while being totally maintenance free. The internal drainage system contributes to the uncluttered beauty of our carefully designed and engineered system. Our in-house chromate conversion coating facility, electrostatic paint-line and ovens offer you considerable finish options on your project.

Diltmer accepts total responsibility on your project, from design and engineering through fabrication, finishing, delivery via our custom trucks and trailers, to erection by extensively trained factory mechanics. Budget figures and design assistance are as close as your phone, or for the services of our nearest representative, call, toll free, Sweet's "BuyLine" 800-663-1180.



# ditt-deck

## specifications

**General:** Aluminum Walkway Cover or Canopy shall be entirely of anodized aluminum extrusions. Understructure shall consist of hell-arc welded one-piece rigid bents and the deck of interlocking anodized aluminum extrusions, as manufactured by Dittmer Architectural Aluminum, 1006 Shepard Road, Winter Springs, Florida 32708. The structure shall be capable of sustaining severe icing, hail, hurricane winds and being walked upon.

**Materials:** All sections shall be 6063 alloy heat-treated to a T-6 temper. Deck screws shall be type 18-8 stainless steel, sealed with neoprene "O" ring beneath stainless steel; trim rivets may be aluminum. A dip-coat of clear acrylic enamel shall insulate column ends from electrolytic reaction with grout. Grout shall be 3:1 Portland cement to masonry sand, 2000# compressive strength.

**Internal Drainage:** Water flow is directed from deck to beams and columns, as indicated by the drawings, for discharge out "weepholes" at ground level.

**Bent Construction:** Anodized beams and columns shall be hell-arc welded into rigid, one-piece units in the manufacturer's plant. Column ends shall be pierced to "key" grout to bent for maximum uplift protection.

**Roof Deck:** Extruded, self-flashing deck sections interlock into a composite unit, spanning double-bays for superior loading. Deck shall be staked into a camber sufficient to off-set deadload deflection and to cause positive drainage on spans over 15'-0". Staking shall consist of an abrupt local deformation of deck-lock metal, each stake having a shear value in excess of 350# and shall occur as detailed.

**Finish:** STANDARD FINISH shall be satin anodized 204-RL, per Aluminum Association Specification AA-M-10C-22A-21, HARDCOAT bronze, amber or black color anodizing shall be per AA-M-10C-22A-42 on KB-45 controlled billet, color to selected. PAINTED FINISH shall consist of baked acrylic enamel, for maximum chalk and fade resistance, over chromate conversion pretreatment on deck and fascia. Bents, after solvent cleaning, shall receive one coat of vinyl wash-etch primer (MIL #125-890) and a 1 mil. minimum coating of exterior grade, two-part, polyurethane for maximum abrasion resistance and maintainability.

**Dimensions:** Contractor shall field-confirm bent location, dimensions and elevations as shown on shop drawings prior to fabrication by Dittmer.

**Erection:** Sleeves (styrofoam block-outs) shall be furnished by Dittmer and set by General Contractor. Dittmer, or authorized installer, shall be scheduled to erect after all adjacent roofing and masonry have been completed. Concrete footings, anchor bolts and/or flashing, where required, shall be by others. Bents shall be carefully aligned prior to grouting; downspout column interiors shall be grouted to lower edge of "weephole"; deflectors shall be installed after grouting. All deck ends at beam joints shall be capped as detailed. Butt and miter joints shall be executed in a workman like manner.

**Approval:** Written approval of the architect must be obtained 10 days prior to bid opening. Interested manufacturers must furnish full details of proposed product, engineering calculations on all sections involved, physical samples of all shaped, and a list of installations similar in size and design.

## extruded aluminum decks

<b>S.S. Eight</b>		Sx = 3.99 in <sup>4</sup> Ix = 0.993 in <sup>4</sup>	Span	6'	7'	8'	9'	10'		
			Stress Limit	320	235	180	142	115		
			Deflection Limit	102	65	43	30	22		
<b>Stretch 60</b>		Sx = 1.93 in <sup>4</sup> Ix = 2.49 in <sup>4</sup>	Span	8'	9'	10'	11'	12'	13'	14'
			Stress Limit	203	161	130	108	90	77	66
			Deflection Limit	122	85	63	46	36	28	22
<b>Standard 60</b>		Sx = 1.48 in <sup>4</sup> Ix = 2.95 in <sup>4</sup>	Span	8'	9'	10'	11'	12'	13'	14'
			Stress Limit	226	179	145	120	100	88	74
			Deflection Limit	138	95	70	52	40	32	25
<b>Spread 80</b>		Sx = 2.08 in <sup>4</sup> Ix = 3.60 in <sup>4</sup>	Span	12'	13'	14'	15'	16'	17'	18'
			Stress Limit	143	122	105	91	80	71	63
			Deflection Limit	62	48	39	32	26	22	18
<b>Sturdy 65</b>		Sx = 2.39 in <sup>4</sup> Ix = 5.31 in <sup>4</sup>	Span	12'	13'	14'	15'	16'	17'	18'
			Stress Limit	164	140	121	105	92	82	73
			Deflection Limit	91	71	57	46	38	32	27
<b>Six X Six</b>		Sx = 4.10 in <sup>4</sup> Ix = 12.31 in <sup>4</sup>	Span	16'	17'	18'	19'	20'	21'	22'
			Stress Limit	160	142	126	113	102	93	85
			Deflection Limit	89	74	62	53	45	39	34
<b>Soffit</b>		Sx = 2.25 in <sup>4</sup> Ix = 3.94 in <sup>4</sup>	Span	10'	11'	12'	13'	14'	15'	16'
			Stress Limit	225	186	156	133	115	100	88
			Deflection Limit	116	87	67	53	42	35	28

Tables show allowable loads (lbs. per sq. ft.) All extrusions are 6063-T6. Safety factor of 2.1 Yield: 31,000 psi. Figures based on breaking deck at alternate bents.

# heli-arc welded bents

## beams

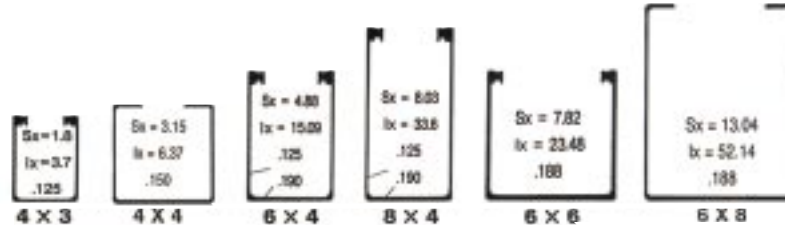

## columns

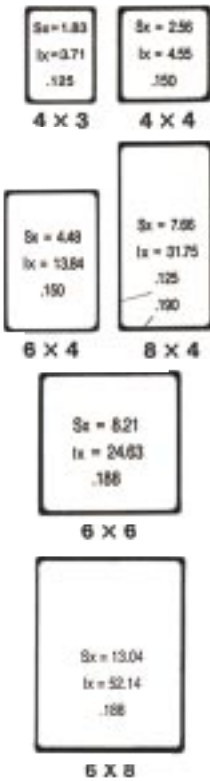

Model	Deck Width									
	6'	8'	10'	12'	14'	16'	18'	20'	22'	24'
<b>U BENT</b>										
1	4x3/4x3	5,134	3,565	2,680	2,110					
2	6x4/4x4	10,338	7,384	5,680	4,544	3,725	3,104	2,587	2,192	
3	6x4/6x4	12,950	9,250	7,115	5,692	4,666	3,888	3,240	2,746	2,367
4	8x4/4x4	14,589	10,727	8,513	6,978	5,815	4,928	4,248	3,694	3,212
5	8x4/6x4	17,508	12,872	10,135	8,108	6,922	5,867	5,058	4,323	3,726
6	8x4/8x4	20,657	15,189	11,960	9,724	8,103	6,867	5,920	5,148	4,477
7	6x6/6x6	16,330	13,090	11,050	9,840	8,590	7,760	7,100	6,560	
8	8x6/6x6	21,616	16,830	13,991	11,978	10,565	9,503	8,663	7,939	7,386
9	8x8/6x6	28,402	22,950	19,405	16,915	15,070	13,600	12,461	11,424	10,591

1	4x3/4x3	3,869	2,954	2,308						
2	6x4/4x4	8,340	6,318	4,936	3,786	3,004	2,612	2,375	2,262	
3	6x4/6x4	9,258	7,014	5,480	4,246	3,397	2,954	2,685	2,558	2,436
4	8x4/4x4	12,855	9,739	7,609	6,136	4,989	4,123	3,465	2,962	2,533
5	8x4/6x4	14,194	10,753	8,401	6,830	5,553	4,589	3,856	3,295	2,841
6	8x4/8x4	16,749	12,689	9,913	8,059	6,553	5,415	4,550	3,889	3,352
7	6x6/6x6	15,730	11,780	9,440	7,900	6,800	5,970	5,330	4,820	
8	8x6/6x6	21,734	16,949	14,060	12,104	10,693	9,503	8,432	7,573	
9	8x8/6x6	25,236	19,005	15,291	12,825	11,030	9,732	8,693	7,862	

Model	DIM. A									
	4'	6'	7'	8'	10'	11'	12'	14'	15'	16'
<b>TT BENT</b>										
	DIM. B									
	1'	1'	1.5'	2'	2'	2.5'	3'	3'	3.5'	4'
1	4x3/4x3	11,918	8,277	6,323	4,800	3,952	3,239	2,699		
2	6x4/4x4	25,581	18,272	14,055	11,244	9,216	7,680	6,508	5,610	4,921
3	6x4/6x4	28,458	18,897	14,536	11,629	9,532	7,943	6,731	5,803	5,089
4	8x4/4x4	33,443	25,591	19,363	16,002	13,795	12,317	11,300	10,561	9,963
5	8x4/6x4	37,059	27,249	21,456	17,732	15,296	13,649	12,522	11,703	11,040
6	8x4/8x4	43,729	32,154	23,318	20,924	18,038	16,105	14,776	13,809	13,027
7	6x6/6x6			24,500	24,530	20,520	17,790	17,710	15,695	14,150
8	8x6/6x6			32,606	32,801	26,940	23,094	23,018	20,255	18,139
9	8x8/6x6			42,432	42,262	35,470	30,804	30,498	27,058	24,403

Model	DIM. A									
	5'	6'	9'	10'	12'	13'	15'	16'	18'	20'
<b>T BENT</b>										
	DIM. B									
	1'	2'	1'	2'	2'	3'	3'	4'	4'	4'
1	4x3/4x3	5,979	4,983	3,691	2,977	2,481	2,130			
2	6x4/4x4	12,403	10,336	7,656	6,174	5,145	4,039	3,606	3,339	3,092
3	6x4/6x4	14,031	11,892	8,691	6,986	5,821	4,690	4,161	3,853	3,567
4	8x4/4x4	21,031	17,518	12,976	10,466	8,720	7,638	6,820	6,046	5,596
5	8x4/6x4	22,855	19,046	14,108	11,377	9,481	7,986	7,130	6,612	6,122
6	8x4/8x4	26,968	22,473	16,647	13,425	11,188	9,423	8,413	7,802	7,224
7	6x6/6x6		17,140	14,380	12,040	10,110	8,920	8,170	7,520	6,880
8	8x6/6x6		25,738	21,564	17,936	15,028	13,209	12,155	11,211	10,156
9	8x8/6x6		28,241	23,655	19,826	16,630	14,671	13,434	12,342	11,254



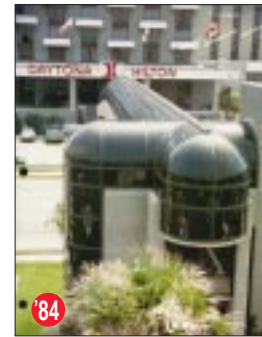
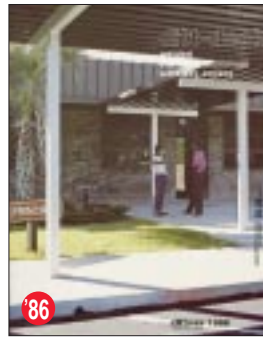
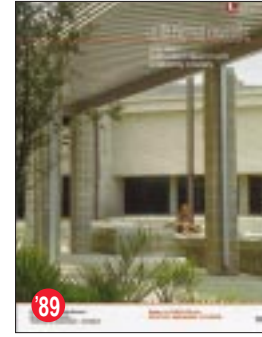
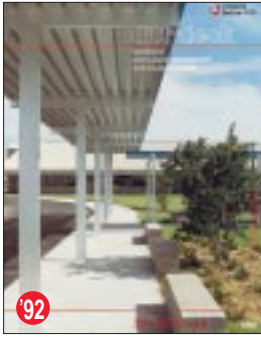
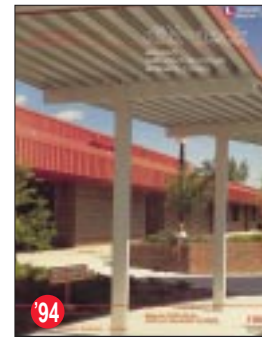

Call for our nearest representative to service your inquiries:  
 800/822-1755 or  
 Sweets Buyline 800/633-1180

Owned and operated by Walt Dittmer, Jr., since incorporating in 1963.



1006 Shepard Road  
 Winter Springs, FL 32708  
 (407) 699-1755 • FAX (407) 695-4430  
 (800) 822-1755